

THIS DRAWING IS UNPUBLISHED. RELEASED FOR PUBLICATION  
 © COPYRIGHT BY TYCO ELECTRONICS CORPORATION. ALL RIGHTS RESERVED.

LOC		DIST		REVISIONS			
P	LTR	DESCRIPTION		DATE	DWN	APVD	
B		EC 063B 0214 05		25AUG05	BSV	CJ	

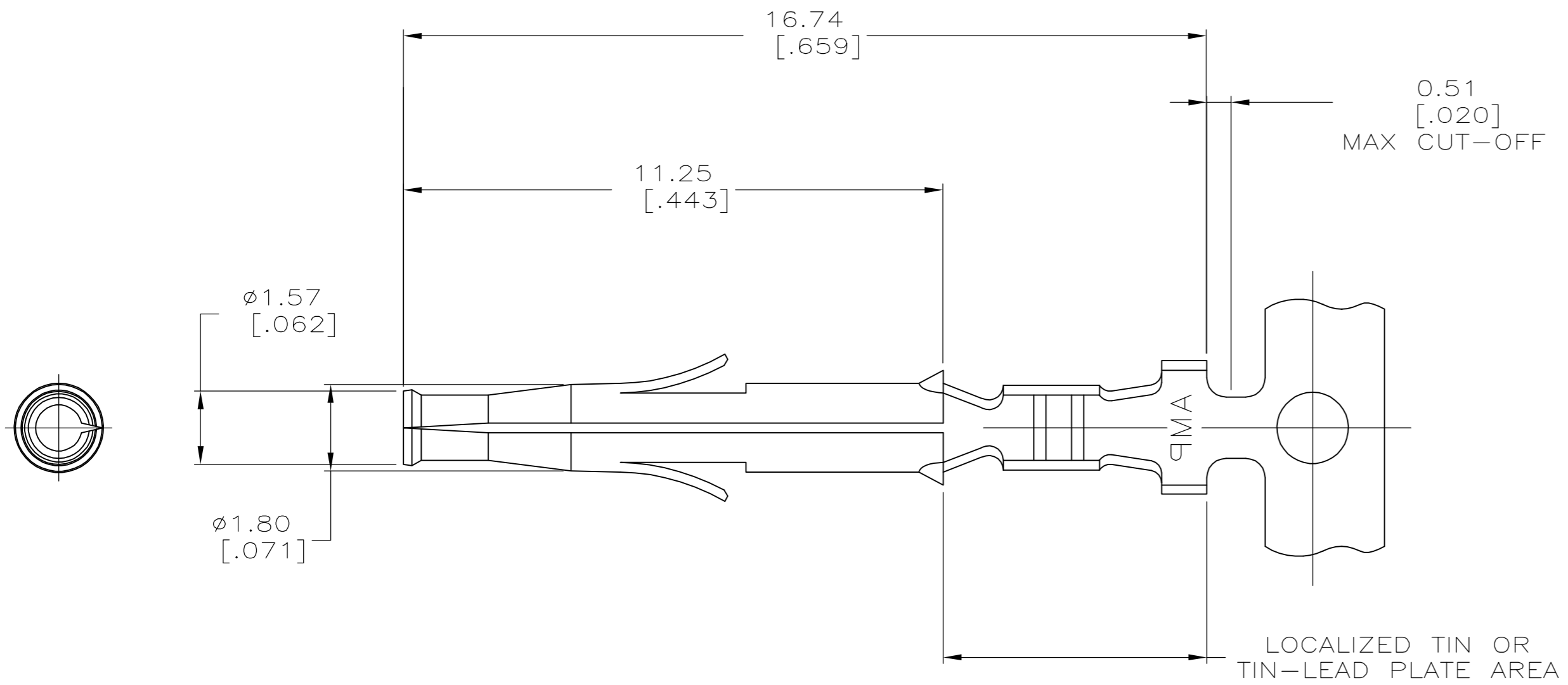

- 1. 0.00076 [.000030] MIN GOLD IN LOCALIZED GOLD PLATE AREA AND 0.00254 [.000100] MIN BRIGHT TIN-LEAD IN LOCALIZED TIN-LEAD PLATE AREA OVER 0.0013 [.000050] MIN NICKEL.
- 2. WIRE RANGE: 0.12 - 0.4mm<sup>2</sup> (26-22 AWG).
- 3. INSULATION RANGE :1.20-1.75[.047-.069] DIA.
- 4. DIMENSIONS IN BRACKETS ARE IN INCHES.
- 5. 0.00076 [.000030] MIN GOLD IN LOCALIZED GOLD PLATE AREA AND 0.00254 [.000100] MIN MATTE TIN IN LOCALIZED TIN PLATE AREA OVER 0.0013 [.000050] MIN NICKEL.

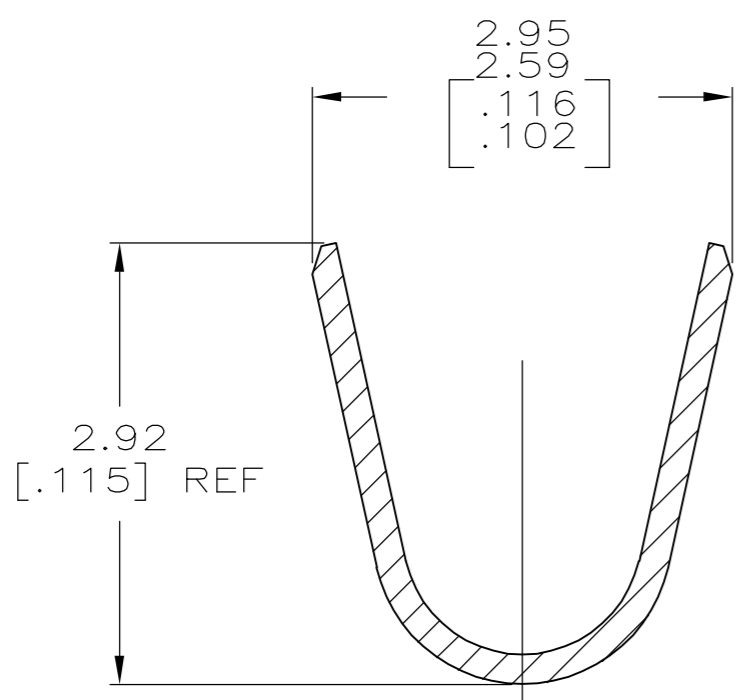
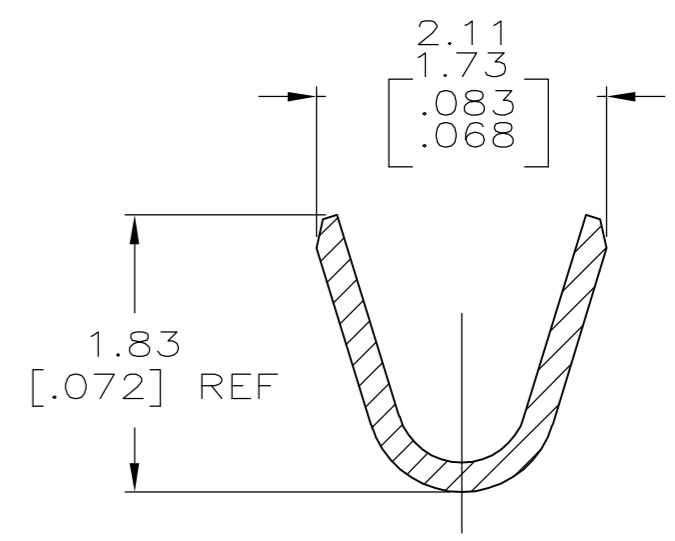
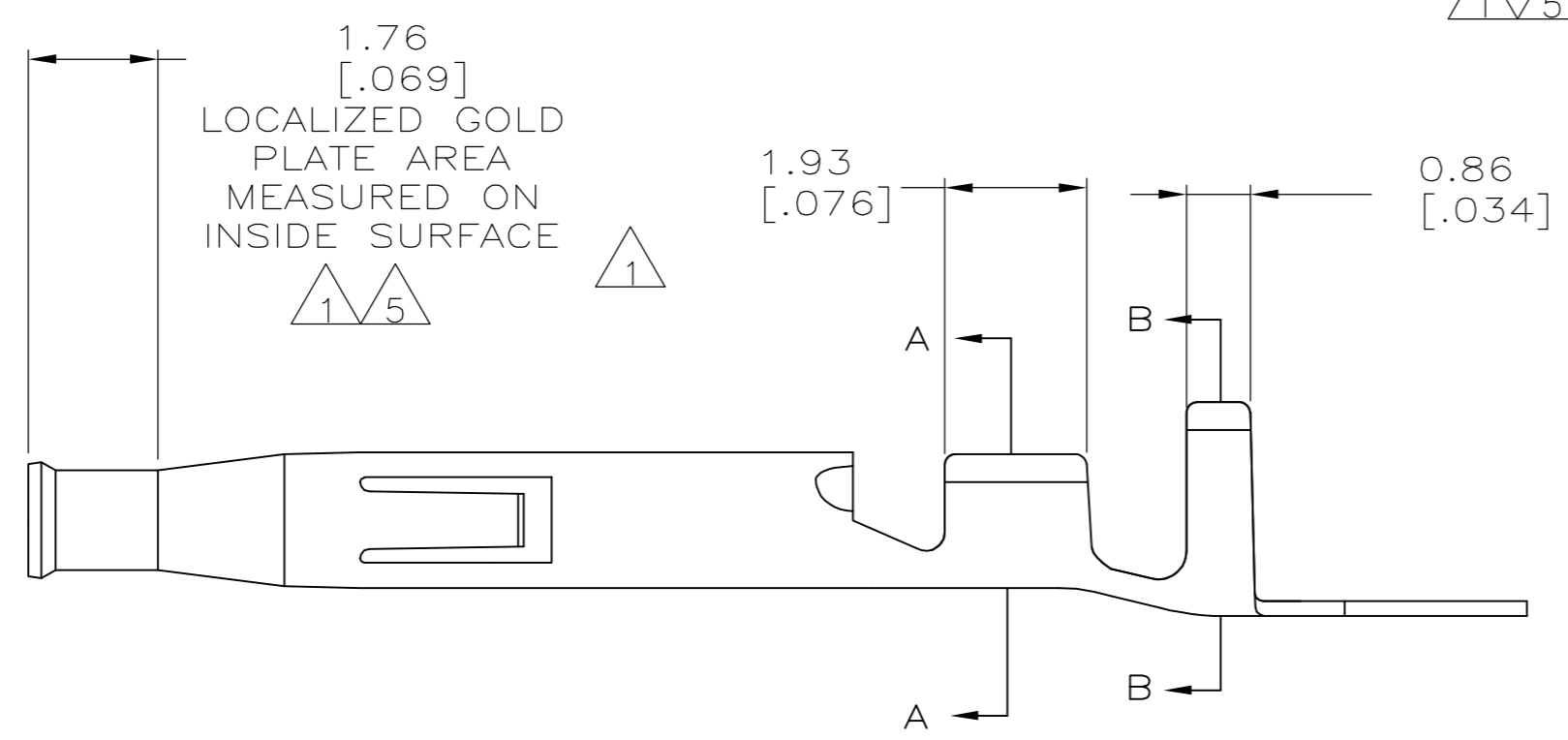

5	0.20 [.008] BRASS	1-794136-0
1	0.20 [.008] BRASS	794136-3
PRE-TIN	0.20 [.008] BRASS	794136-1
FINISH	MATERIAL	PART NUMBER

THIS DRAWING IS A CONTROLLED DOCUMENT.		DWN	R.VESTAL	22OCT96	 Tyco Electronics Corporation Harrisburg, PA 17105-3608
DIMENSIONS: mm [INCHES]		CHK	R.SWING	22OCT96	
TOLERANCES UNLESS OTHERWISE SPECIFIED:		APVD	R.ORSTAD	22OCT96	
0 PLC ± - 1 PLC ± - 2 PLC ± - 3 PLC ± 0.15[.006] 4 PLC ± - ANGLES ± 1°		PRODUCT SPEC	NAME		
MATERIAL	SEE TABLE	APPLICATION SPEC	SOCKET, MINI UNIVERSAL MATE-N-LOK(TM)		RESTRICTED TO
CUSTOMER DRAWING		WEIGHT	-	SIZE	A2
SCALE		CAGE CODE	00779	DRAWING NO	C=794136
SCALE 10:1		SHEET	1 of 1	REV	B

METRIC